

### Traffic lights ATL

LED traffic lights for optimal signalling.

#### Features

- Energy saving
- Strong light
- Very long life, no wear and tear
- High impact resistance
- Less heat
- Spray waterproof housing (IP 65)
- Environmentally friendly
- Available in two different models

### Application

The traffic lights increase safety around the loading and unloading platforms. The light can be easily connected to the control box of the dock leveller, inflatable dock shelter or industrial door.

Once the industrial door is opened or the docking equipment is operated, the light turns from green to red. When loading and unloading is completed or the door is closed, the light turns from red to green and the truck driver knows that it is safe to drive away.

Inside the building, signal lights can be installed on the control box which operate in the opposite way to the traffic lights outside.

The traffic signal lights inside and outside can also operate in combination with a wheel chock or vehicle detection sensor.

### Long life and energy saving

The traffic lights have a long life with over 50,000 hours. The traffic lights have low energy consumption and are therefore energy saving.

### Materials

The large quantity of LED's produce intense light which is highly visible. The traffic lights are shock resistant and have a spray-proof housing (IP 65).

### Dimensions

The traffic lights are available in 2 models on which the red and green light each have a diameter of 100 mm or 200 mm.

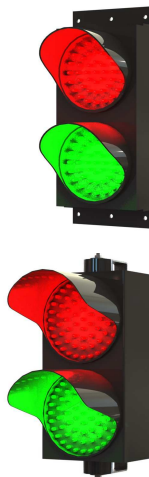
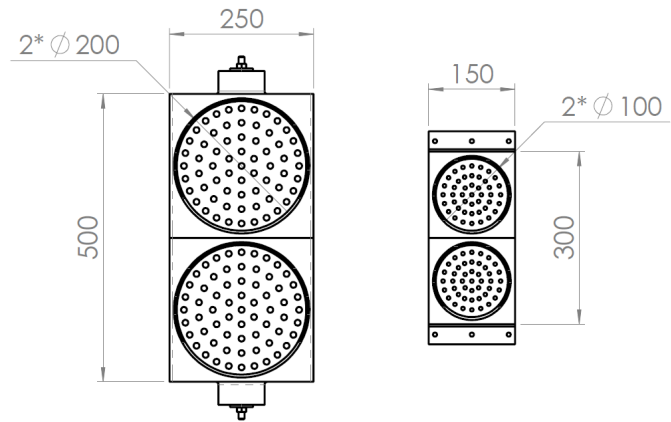

Article nr.	Width (mm)	Height (mm)	Depth (mm)	Diam. lens (mm)	Power	Weight (kg)
ATL-100-220	150	300	61	100	220V AC	5,2
ATL-100-24	150	300	61	100	24V DC	5,2
ATL-200-220	250	500	140	200	220V AC	5,94
ATL-200-24	250	500	140	200	24V DC	5,94

### Technical specifications ATL-100-220 / ATL-100-24

Standards.....CE  
 Life span.....50.000 – 80.000 hour  
 Power consumption.....<= 12 W  
 Power connection.....24V DC or 220V AC, 50Hz  
 LED quantity..... red and green light each 45 pieces  
 Wave length.....red colour 625±5 nm and green colour 505±5 nm  
 Licht intensity.....red > 150 cd and green > 300 cd  
 Protection class.....IP65

### Technical specifications ATL-200-220 / ATL-200-24

Standards.....CE  
 Life span.....> 50.000 hour  
 Power consumption.....<= 21 W  
 Power connection.....24V DC or 220V AC, 50Hz  
 LED quantity..... red and green light each 90 pieces  
 Wave length.....red colour 625±5 nm and green colour 505±5 nm  
 Licht intensity.....red > 300 cd and green > 500 cd  
 Protection class.....IP65

### Installation options

The small model (ATL-100) is mounted directly on the wall and the large model (ATL-200) has an adjustable mounting bracket.

### Options

- Signal lights on control box (indoor)